

FOR PUBLIC DISTRIBUTION



PRESS RELEASE

**Airforms, Inc. awarded new engine baffle FAA PMA approval
Baffle kits now available for Piper PA-44-180 Seminole**

#

BIG LAKE, ALASKA, 16-Sept-14 -- Airforms, Inc. growing line of replacement aircraft engine baffles now includes components for all Piper PA-44-180 Seminole twin engine aircraft. Airforms’ engineering department received the new PMA (Part Manufacturing Approval) this week through its continued work with the FAA Anchorage ACO (Aircraft Certification Office). The new Piper baffles add to an existing product line of over 50 unique FAA PMA engine baffle kits for a wide range of aircraft.

“As we move forward with the expansion of the Airforms engine baffle line, we continue to respond to the needs of the flight training providers. Our new PA44-180 engine baffles provide a durable solution for long product life – even in the rigorous and demanding training market,” said Airforms’ Sales & Marketing Executive, Steve Hunter. “These new baffles will stand up to the most challenging operating conditions, providing a real value for the operators in this highly competitive field. All of the parts in our most recent Piper baffle releases are designed for longer life and increased serviceability – with pricing that makes them affordable for all of our customers.”

The replacement Seminole baffle kits represent the next evolution in Airforms’ engine baffle product line, and are eligible for installation on all normally aspirated PA44-180 aircraft – from 1979 through current production. Airforms’ baffles feature a bare metal or durable powder coat finish, and incorporate design reinforcements with longer lasting materials, and feature a range of seal options. All baffles are designed to be precise replacements for the original parts.

Airforms, Inc. is a growing aeronautical design and production company located in Big Lake, Alaska. Airforms is an industry leading supplier of replacement engine baffles for a wide range of general aviation aircraft; products also include a select and expanding line of turboprop aircraft PMA parts and STCs. Airforms maintains a FAA approved manufacturing system for PMA parts, supported by an engineering department with FAA DER staff.

For more information, including a secure online marketplace and catalog with photographs, visit www.airforms.biz. Airforms’ operates from 7 AM to 7 PM CST on all business days and can be reached directly at 907-892-8244.

#

(see photo on page 2)

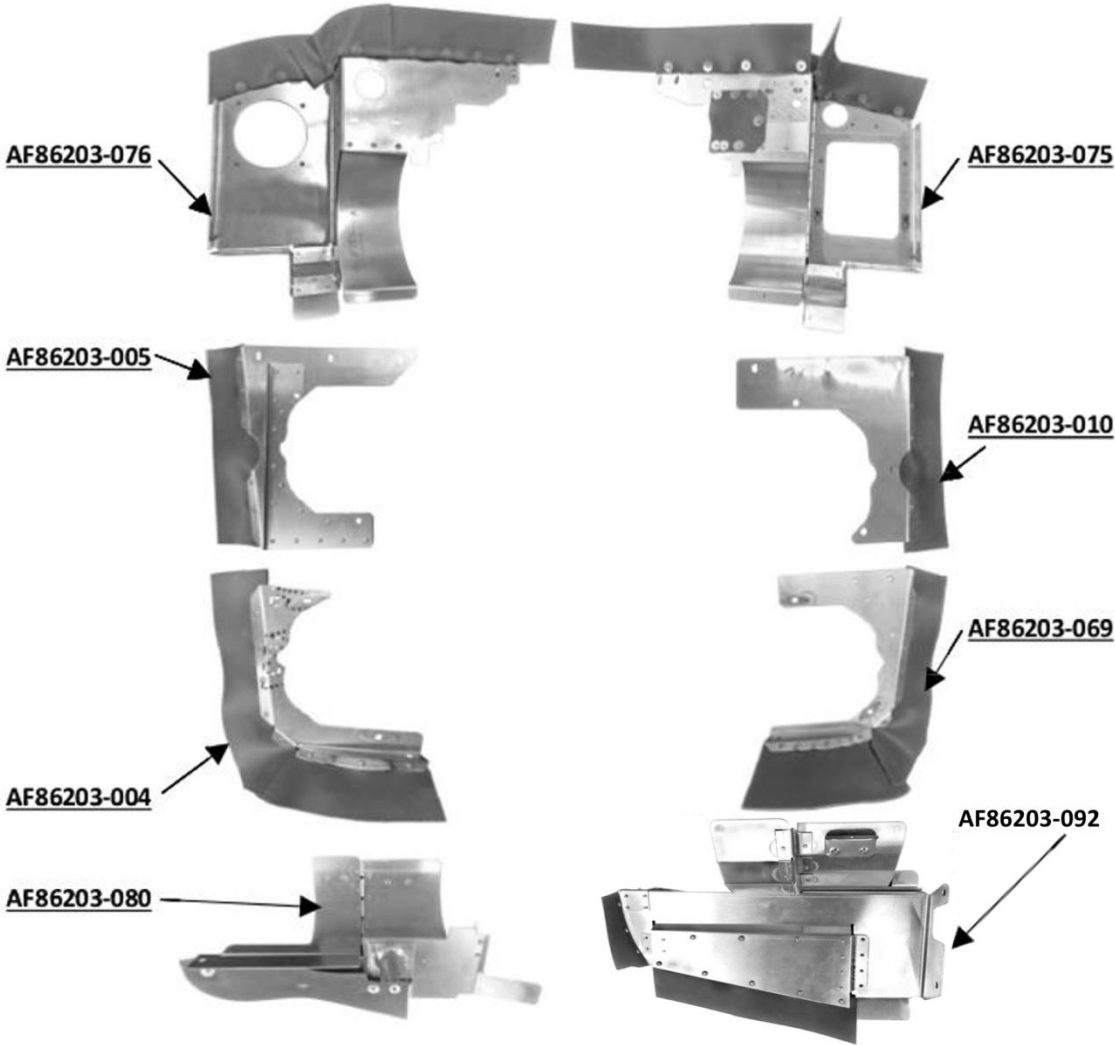

Photo 1: Airforms’ engine baffles for PA-44-180 Seminole aircraft